



HR hot water & heating boilers



hurlcon HR heating and hot water boilers

In just over a decade, Hurlcon gas boilers have become the dominant force in the swimming pool and spa heating market.

Now the HR Series boilers make that technology available for the commercial hot water supply, heating water applications, and commercial swimming pools. Their flexibility and performance make them ideal for:

- Wineries.
- Abattoirs.
- Hospitals.
- Hotels.
- Schools.
- Commercial Laundries.
- Micro Breweries.
- Multi-unit Dwellings.
- Hairdressing Salons.
- Gymnasiums.
- Commercial Kitchens.

They are also perfect for:

- Wash-down areas.
- Commercial air conditioning systems.
- Water-sourced heat pumps.
- Centralised hot water.
- Sterilisation.

Hurlcon's success is built on four key factors. All Hurlcon boilers are amazingly reliable - almost indestructible. They are safe, easy to use and install and they offer great value for money.

Like the successful pool heaters, the HR Series boilers are 'direct-fired'.

The extruded copper finned tubes have lower water content and do not require a secondary heat exchanger or calorifier so they are:

- Faster to heat-up and cool-down.
- Lighter weight.
- More flexible and...
- Much, much less expensive to buy and maintain

They incorporate leading-edge boiler technology, including:

- An all copper, high-fin heat exchanger.
- Bronze headers with brass sensor pockets.
- Corrosion resistant stainless steel burners.
- A built-in flow-switch at no extra cost to protect the boiler.

- A built-in draught-diverter for indoor installations reducing installation costs
- A weather-proof balanced flue for outdoor installations provides reliable performance even in high winds.
- Fully powder-coated zincalume steel cabinet coated both sides for longer life.
- Powder-coated flue terminal for high temperature resistance and longer life.
- Intermittent pilot for reliable lighting.
- A built-in run-on timer as standard for pump connection and ample space to mount a contactor for 3 phase pumps.
- A manual reset high limit to protect against over temperature.

All of which justifies a 5 year warranty on the heat exchanger and 12 months on all other parts.

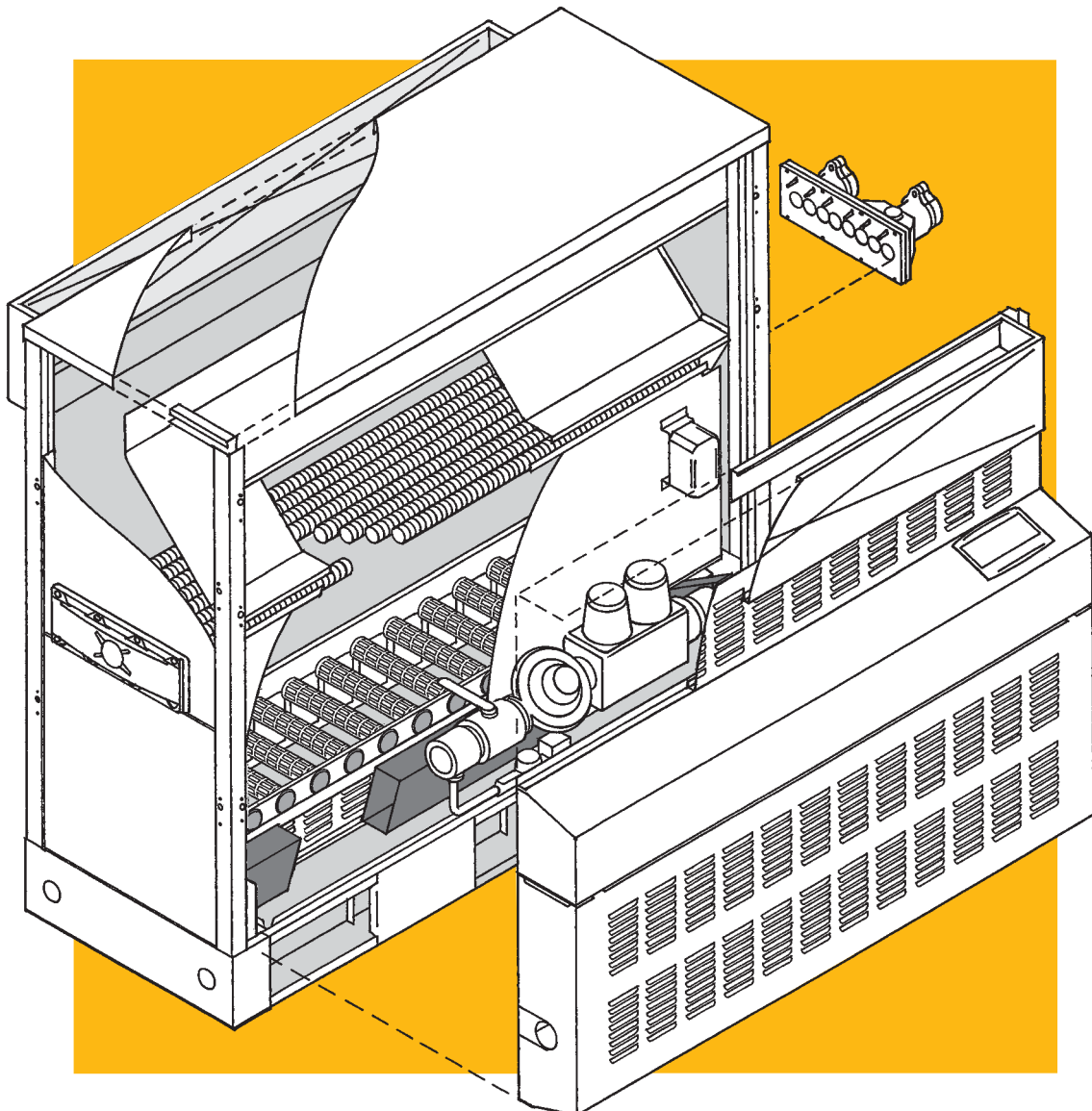

hurlcon HR heating and hot water boilers

Perhaps the greatest gain from the Hurlcon pool and spa boilers is in their electronics and operating systems.

The HR Series boilers provide the ultimate in convenience and control.

Operational Ease and Accuracy.

- Modulating models have PID control with auto tune to maintain accurate water temperature and lower operating costs.
- They also have a set point shift input providing low cost integration to BMS systems.
- All have set and flow temp displays provide accurate information at a glance.
- All have electronic ignition to improve efficiency and lower operating costs.

Even installation is simplified:

- Only requires a 10A 240v supply.
- Flow-switch and pump run-on timer are built-in.
- A terminal strip for pump, room thermostat, outdoor compensation and run and fault status.

Hurlcon HR Boiler Flow Rates in litres per second.

Model	Input MJ/hr	Output kW	At 10° C Rise		At 15° C Rise		At 20° C Rise	
			Flow Ltr/sec	Pressure Drop kPa	Flow Ltr/sec	Pressure Drop kPa	Flow Ltr/sec	Pressure Drop kPa
HR 600	594	136	3.44	8.0	2.29	3.9	1.72	2.8
HR 800	792	180	4.56	13.0	3.04	7.6	2.28	4.7
HR 1000	990	225	5.71	17.0	3.81	10.5	2.86	7.8
HR 1200	1188	270	6.86	17.8	4.57	13.5	3.43	7.8
HR 1400	1386	316	8.00	29.0	5.34	18.0	4.00	9.2
HR 1600	1584	361	9.15	35.0	6.10	24.0	4.58	11.0
HR 1800	1782	406	10.30	36.0	6.87	26.0	5.15	12.0

Hurlcon HR Boiler Recovery Rates in Litres per Hour.

Model	Temp Rise	30°	40°	50°	60°	70°	80°	Suggested Minimum Buffer [Tank Size / Litres]	Min Ring Main Capacity
HR 600		4129	3097	2477	2065	1770	1548	400	50
HR 800		5477	4108	3286	2738	2347	2054	400	50
HR 1000		6853	5140	4112	3427	2937	2570	400	50
HR 1200		8229	6152	4938	4115	3527	3086	600	60
HR 1400		9606	7204	5763	4803	4117	3602	1000	80
HR 1600		10982	8237	6589	5491	4707	4118	1000	100
HR 1800		12358	9269	7415	6179	5296	4634	1000	150

When a product such as the HR Series combines Hurlcon's legendary reliability and accuracy with real efficiency it represents exceptional value-for-money.

Low-Cost Operation.

- Extruded Copper High fin heat exchanger for maximum efficiency
- Super efficient stainless steel burners with sophisticated venturi and gas/air mixing baffle.
- A built-in run-on timer maximises heat gain.



HR Modulating Models also boast:

- Built-in outdoor compensation. To reduce both add-on and running costs simply add an outdoor sensor.
- And a modulation down-turn of 5:1 allows precise water temperature management without over or under shooting.

hurlcon HR heating and hot water boilers

Big Performance, Compact Design.

Space restrictions are common in many commercial installations.

The Hurlcon HR Series Boilers are designed to deliver large scale output from a compact, easy to install package.

Inside, everything is designed to save space. Outside, with the removal of a few panels, HR will even fit through a standard doorway making retrofit plant room installations simple.

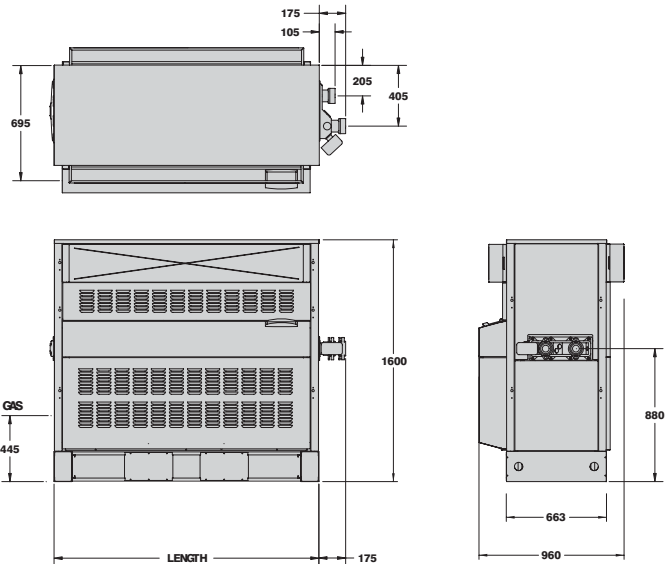

System Dimensions.

Model	Flue Size	Gas Connection mm	Water Connection F.I. mm	Water Content [litres]	Width mm	Height mm	Length mm
HR 600	255mm	25	40	9.5	935	1600	1250
HR 800	305mm	40	40	10.2	935	1600	1450
HR 1000	405mm	40	40	10.8	935	1600	1650
HR 1200	405mm	40	50	11.4	935	1600	1850
HR 1400	455mm	40	50	12.0	935	1600	2050
HR 1600	455mm	40	50	12.6	935	1600	2250
HR 1800	455mm	40	50	13.2	935	1600	2450

Due to our policy of continuous improvement, we reserve the right to change specifications without notice.

Please check and confirm calculations before committing to a boiler capacity.

To download a sample tender specifications on any Hurlcon product, visit the website at www.hurlcon.com.au

Sample Specification HR Series Hot Water Boilers [Modulating Water model variations in brackets]. Boiler shall be a Hurlcon HR Series model HR _____ rated at ____ kW output and ____ MJ input. The heat exchanger shall be of copper finned tube with one piece extruded integral fin. The tubes shall be mechanically expanded directly into bronze headers to prevent water leaks from silicone gaskets. Unit shall be standard with flow switch, voltage free run and fault contacts and

pump run on timer. Burners shall be stainless steel with venturi design and mixing baffle to ensure even flame distribution along entire length of burner. Refractory material shall be low density Superwool to prevent excess heat storage. Marine grade powder coated panels shall be easily removable for servicing and burner removal. Boiler shall have integral outdoor weatherproof flue design for outdoor installation and integral draft diverter for indoor installation. Ignition shall be electronic IID with

pilot. On HR ON/OFF Boilers, temperature control will be achieved by the integrated Genus IV controller sensing entering water temperature. The controller shall have an incorporated diagnostic fault display. [On HR Modulating Boilers, temperature control will be achieved by the integrated Siemens PID controller sensing leaving water temperature and shall modulate down to 20%. The controller shall be capable of outdoor ambient compensation control.]

Available from:



Order Free Fax 1800 635 781 or sales@hurlcon.com.au

Victorian Office:
Ph: 03 9765 9765
Fax: 03 9764 9009

NSW Office:
Ph: 02 9674 8544
Fax: 02 9674 8522

Queensland Office:
Ph: 07 3393 3233
Fax: 07 3393 3255

South Australian Office:
Ph: 08 8345 5755
Fax: 08 8345 5211

Western Australian Office:
Ph: 08 9258 9322
Fax: 08 9258 9344