

ASTRALPOOL 

Hurlcon Pumps

CTX Series, E Series

BX Series & FX Series

INSTALLATION AND OPERATING INSTRUCTIONS



Melbourne: 03 8796 8600
Sydney: 02 9853 2100
Brisbane: 07 3308 5400

Gold Coast: 07 5552 2600
Townsville: 07 4750 3100
Adelaide: 08 8152 7600

Perth: 08 9350 2600
sales@astralpool.com.au
www.astralpool.com.au

A division of

FLUIDRA

GENERAL

A high performance, high head pump ideally suited for the modern pool or spa with extensive equipment such as chlorinators, heaters and in floor cleaning.

Note:

The appliance is not intended for use by young children or infirm person without supervision. Please ensure that young children are supervised to ensure that they do not play with the appliance.

FEATURES

- Continuous duty rated motor
- Precision reinforced moulded high head impeller, giving extra performance
- Single piece moulded body for added strength and longer life
- Rapid priming diffuser quickly corrects loss of water flow
- Quick and easy disassembly for servicing
- Large capacity basket with easily removed ramp on lid

DIMENSIONS

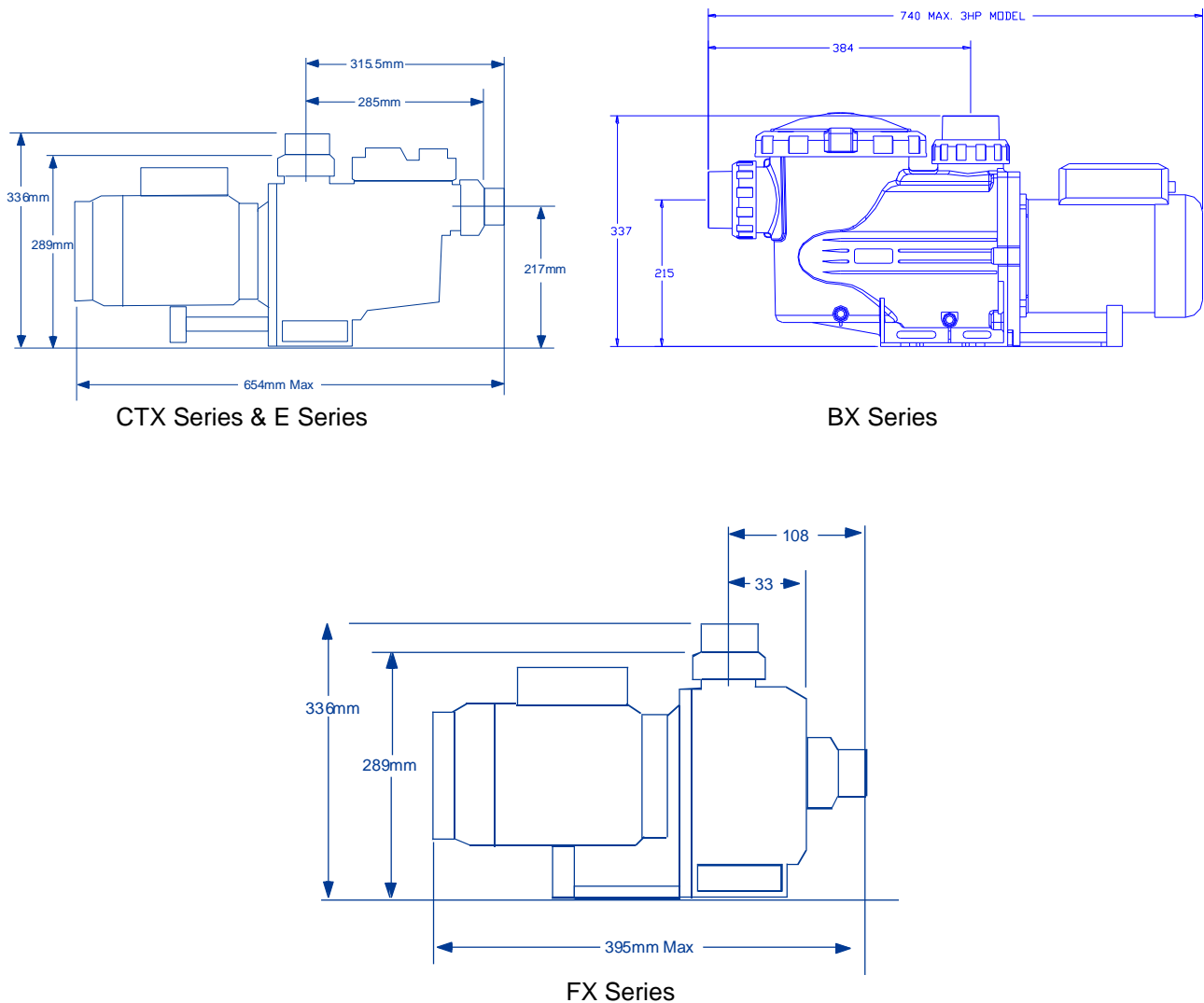

INSTALLATION OF BX, CTX & E SERIES PUMPS

- A.** Plan position of pump so that it will be:
1. Free of water flooding, such as in a sump, garden hollow, ditch or at the bottom of a bank.
 2. On a stable base so that:
 - a) The pump is not left suspended by its fittings, causing a leak or failure with loss of water.
 - b) Movement through vibration is restricted
 - c) No strain is put on attaching pipe or other expensive equipment
 3. Accessible for maintenance and easily removed for service.
 4. Breathing space. Pump should not be crowded which will prevent cooling airflow from fan. Overheating due to lack of cooling voids warranty.
 5. Within reach of power point without extension cables as plugs liable to corrosion, shorting, etc.
 6. At a minimum height of suction lift of water from pool surface to pump inlet.
- B.** For best pump performance keep suction pipe length as short as possible with minimum number of bends and use 50mm PVC suction pipe for 750W (1hp) to 1700 W (2.0 hp). On 3.0 hp models a 65mm or 2 x 50mm suction should be used.
- C.** Minimum pipe diameters should be used on the following pumps
40mm - E 140, E190, E230, CTX180 &
50mm - E 290, CTX280, CTX360, CTX400, CTX610, BX1.0, BX1.5, BX2.0, BX3.0
- D.** Secure the barrel unions supplied into the attaching pipe work, using approved priming fluid and solvent cement as normal practice, coating both surfaces. NOTE: Always wear protective gloves when handling and using glue and priming fluid. Ensure no excess adhesive runs into the union proper affecting the sealing or removal abilities. Allow 24 hours to dry before starting pump. Do not use "green" glue on barrel unions. This can cause damage to the ABS material used to manufacture the unions.
- E.** Install isolation valves before the pump section and after equipment, if the pump is below the water level of the pool.
- F.** For pump installations 500mm above water level, it generally requires a foot valve at the pool or check valve in the suction line. Suction lines must be installed below water level until just in front of pump location and vertical riser used to reach pump inlet. Hurlcon pumps are rated to a maximum head of 25 metres however refer to your pumps data plate for actual achievable pressure
- G.** All pumps will operate quieter and perform more efficiently if a straight length of 450mm pipe is plumbed horizontally into the front of the pump.
- H.** Water temperature not to exceed 45 degrees
- I.** Pumps must be either
- supplied by an isolating transformer, or
 - supplied through a residual current device (RCD) with a rated residual operating current not exceeding 30mA.

INSTALLATION OF FX SERIES PUMPS

- A.** Plan position of pump so that it will be:
1. Below the pool or spa water level unless pump is primed to be a secondary pump,
 2. Free of water flooding, such as in sump, garden hollow, ditch or at bottom of bank with run off.
 3. On a stable base so that:
 - a) The pump is not left suspended by its fittings, causing a leak or failure with loss of water.
 - b) Movement through vibration is restricted.
 - c) No strain is put on attaching pipe or other expensive equipment.
 4. Accessible for maintenance
 5. Easily removed for service
 6. Breathing space. Pump should not be crowded which will prevent cooling airflow from fan. Overheating due to lack of cooling voids warranty.
 7. Within reach of power point without extension/plugs liable to corrosion, shorting, etc.
- B.** For best pump performance keep suction pipe length as short as possible with minimum number of bends and use 50mm PVC suction pipe for 750W (1hp) or larger pumps.
- C.** Minimum pipe diameters should be used on the following pumps
- | | |
|--------|---------------|
| 40mm - | FX190, FX 250 |
| 50mm - | FX340, FX520 |
- D.** Secure the barrel unions supplied into the attaching pipe work, using approved priming fluid and solvent cement as normal practice, coating both surfaces. NOTE: Always wear protective gloves handling and using glue and priming fluid. Ensure no excess adhesive runs into the union proper affecting the sealing or removal abilities. Allow 24 hours to dry before starting pump. Do not use "green" glue on barrel unions. This can cause damage to the ABS material used to manufacture.
- E.** Install isolation valves before the pump section and after equipment.
- F.** All pumps will operate quieter and perform more efficiently if a straight length of 450mm pipe is plumbed horizontally into the front of the pump.
- G.** Water temperature not to exceed 45 degrees C.
- H.** Hurlcon pumps are rated to a maximum head of 25 metres however refer to you pumps data plate for actual achievable pressure
- I.** Pumps must be either
- supplied by an isolating transformer, or
 - supplied through a residual current device (RCD) with a rated residual operating current not exceeding 30mA.

3 PHASE PUMP INSTALLATION

To be performed only by a qualified electrician.

1. Connect power to motor
2. Ensure that pump is empty of all water
3. Momentarily apply power to motor and check rotation direction of motor matches that of the arrow located on the rear of the pump seal plate.
4. If motor is rotating in the opposite direction to arrow on pump, correct phase wiring.
5. Once rotation is correct, fill pump with water, prime as described below and test pump operation.

OPERATION OF BX, CTX & E SERIES PUMPS

1. Prime pump if hair and lint pot is dry as follows – Close off valve on suction line if present. Remove lint pot lid. Fill lint pot and chamber with water. Replace and secure lint pot lid and seal.
2. Open all valves, allowing fluid to flow through pump.
3. Switch on power to pump, motor to start.
4. If some flow of water does not establish within on half minute, switch off and prime pump again. If pump does not prime within 3 attempts, check all suction connections for sealing. If these are satisfactory, a check or foot valve is required to hold water for prime.
5. If the water flow through pump is always tedious to obtain at start-up after cleaning the lint basket, then an examination of the system to establish a reason and correct the cause is recommended. Eg. Check valve, air leaks, faulty seal, cracked lint pot lid, etc.
6. A non return valve is supplied loose in the basket of the pump (CTX and E Series only). To install, place between the outlet barrel union tail and the discharge of the pump. The non return valve should be located so that the flap can swing upwards into the union tail. The non return valve should be installed on spas equipped with cartridge filters, any time multiple pumps are operating off one suction or return line or any installation where a back flow of water may occur when the pump is shut down. The non return valve will reduce the performance of the pump slightly.

Notes: The pump is not intended for use by young children or infirm persons without supervision. Please ensure that young children are supervised to ensure that they do not play with the pump.

To avoid a safety hazard, the supply cord if damaged, must only be replaced by AstralPool, or its service agent or a suitably qualified person.

OPERATION OF FX SERIES PUMP

1. Open all valves, allowing fluid to flow through pump.
2. If an air lock occurs and no water appears to fill pump housing once the valves have been opened, release outlet barrel union slowly until a small amount of water escapes from the pump then re-tighten.
3. Switch on power to pump, motor to start.
4. If some flow of water does not establish within on half minute, switch off and repeat procedure 3 again. If pump does not prime within 3 attempts, check all valves and jets are in the open position.

Notes: The pump is not intended for use by young children or infirm persons without supervision. Please ensure that young children are supervised to ensure that they do not play with the pump.

To avoid a safety hazard, the supply cord if damaged, must only be replaced by AstralPool, or its service agent or a suitably qualified person.

MAINTENANCE

Hurlcon pumps are designed to operate for extended periods without any attention or maintenance. Following are the periodic maintenance requirements:

1. Keep the lint basket clean – empty it regularly. Blocked lint basket or suction pipe and no water flow can cause overheating with consequent pipe and pump components failure and meltdown.
2. Apply suitable waterproof grease to the lint pot “O” ring to ensure positive seal.
3. Ensure electrical passage for cooling airflow to prevent fusing or shock hazards.
4. Maintain clear passage for cooling airflow to prevent overheating of motor.
5. Maintain eater in good chemical balance.
6. Do not allow quantities of sand or grit to continuously pass through pump to prevent “sand blasting” erosions (use filter sock in lint basket if and, etc. is being picked up by vacuum.)
7. Do not over tighten strainer lid. Never use a tool or handle to tighten lid, the lid is designed to prevent this from happening.
8. Do not add pool salt, chlorine, acid or other chemicals directly to your skimmer. This may result in damage to your pump and could void your warranty.

WARRANTY

E Series Pumps are covered by a 2 year warranty and BX, CTX & FX pumps are covered by a 3 year warranty as described herein. Your Hurlcon pump is covered against defects in materials and workmanship from the date of purchase (plus 30 days to allow for installation). This warranty is subject to the conditions and limitations herein after stated. You must notify AstralPool of the failure of any component of a pump and motor within the warranty period.

AstralPool will at its option, repair or replace any defective parts.

Component failure must be due solely to a defect in materials or workmanship. This warranty does not apply if failure is due to any abuse, misuse, improper installation or accident or to any of the following:

- Running the pump dry,
- Improper chemical balance in the water,
- Water damage from external sources,
- Inadequate ventilation,
- Cement, pebbles, render or other pool surface finish blocking the impeller,
- Addition of salt, chlorine, acid or other pool chemicals directly to the pool skimmer or pump hair and lint pot
- Use on non swimming pool or spa pool application, (i.e. salt water aquaculture).

To stand behind our commitment to provide warranty coverage, we have established a network of authorised warranty agents throughout Australia. To obtain warranty service, contact our Service Department. If your request for warranty service is diagnosed to be non-warrantable, you will be charged for a diagnostic service call. In field labour warranty is applicable in Capital City Metropolitan areas or within a 20 km radius of an Authorised AstralPool Service Agent.

AstralPool shall have no liability for incidental or consequential damages. No person is authorised to make any representation or warranty on behalf of AstralPool other than what is stated here.

Commercial Installations

On Commercial Installations, such as health clubs, motels/hotels and hydrotherapy, parts and in field labour warranty (within capital city metropolitan areas or 20km radius of authorised service agents) is 12 months from the date of purchase plus 30 days.

AstralPool assumes no liability for consequential damages of any kind.

ASTRALPOOL Pty. Limited. A.B.N. 97 007 284 504
www.astralpool.com.au email: service@astralpool.com.au
Information and specifications subject to change without notice.

Victoria:	New South Wales:	Queensland:	South Australia:	Western Australia:	Gold Coast:	Townsville:
Ph: (03) 8796 8600	Ph: (02) 9853 2100	Ph: (07) 3308 5400	Ph: (08) 8152 7600	Ph: (08) 9350 2600	Ph: (07) 5552 2600	Ph: (07) 4750 3100
Fax: (03) 8796 8670	Fax: (02) 98532170	Fax: (07) 3308 5470	Fax: (08) 81527670	Fax: (08) 9350 2670	Fax: (07) 5552 2670	Fax: (07) 4750 3170